

Use Recommendations for Broaching Operations

Rotating Broach – Rotary Broaching can be performed on turned parts as well as CNC machining centers or transfer-machine. The only difference being that the broach holder is rotated in the machine spindle and the part is stationary instead of the reverse condition on a lathe. Orientation of a profile and part can be accomplished with a drive on the spindle nose which maintains the exact angular position required. In order to produce parts successfully there are some basic rules that must be followed.

Cutting Principle - The tool is held at a 1° angle relative to the part centerline and has a $1^\circ 30'$ clearance angle built in. The face of the broach tool is the pivot of the 1° angle and is placed on centerline with the part. As the tool comes in contact with the part, friction drives the broach to rotate synchronously. The cutting edge is kept on center and the rest of the tool oscillates around the part centerline with a wobble effect. With the faces of the tool and part at a relative 1° angle, only the leading point of the tool is cutting and not the entire profile. The wobble effect moves the leading edge to rotate in and out of the cut like a cam. It shears the shape into the part with a scalloping effect as it advances forward. This reduces the required thrust force up to 80% when it is at the optimum feed.

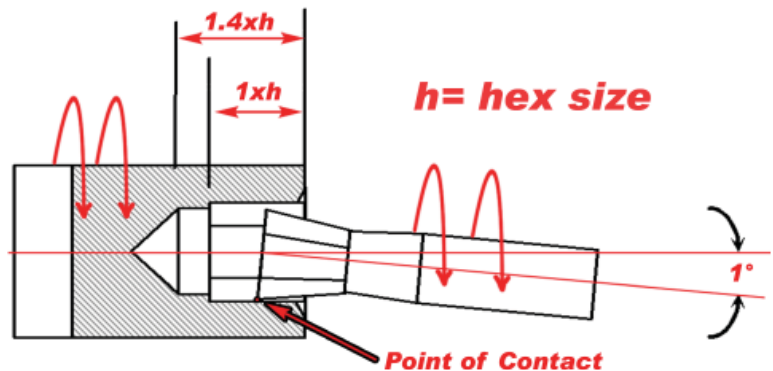

Coolant - Usual coolant or cutting oil

Broach Preparation - A 60° or 90° chamfer, slightly bigger than the largest dimension of the broach, is essential for an easy start of the broach. When exact concentricity is required, counter bore the hole at the same size as the measured profile across corners, boring approximately $.020''$ deep will provide the best results.

Drilling The Hole - For internal broaching, the pilot hole (p) should be drilled approx. 1% bigger than the diameter across the flats of a hex shape (h). This percentage can be reduced in free cutting material and increased as machinability decreases. In mild steel we recommend the following tolerances:

h = hex broach diameter / p = pilot hole diameter

h = .059" - .118"

h = .118" - .236"

h = .236" - .394"

h = .394" - .630"

h > .630"

p = h + .001" - .002"

p = h + .0015" - .0035"

p = h + .0025" - .005"

p = h + .004" - .008"

p = h + .006" - .012"

Drill Radius Not Allowed - When a drill radius is not allowed along the broached walls of the part, tool life and bearing life will be reduced. When exact concentricity is required, c'bore, drill and pre-bore the hole which will keep the broach concentric when it enters the hole. With such a tight fit push back may result as the broach becomes a hydraulic ram. This pressure can be relieved with a vent hole supplied in the broach tool.

Drilling Depth - Drill the hole as deep as possible to leave room for chip accumulation. We recommend a depth of 1.3 to 1.5 times the length of the profile depth. Failure to drill to an adequate depth will cause premature tool life and will damage the broach head.

Centering The Broach - Nothing is more important than having the cutter centered as close as possible to the center of the work piece. Improper center setting will cause an uneven hole configuration, oversize holes and spiraling. The maximum eccentricity should not exceed $.0008''$. To simplify setup on more accurate Swiss Type and Gang Machines, use our (on-center) 2100 Series holders. For easier setting on conventional CNC and other machines, use our gages 6189 or 6199 with the adjustable type broaching heads.

Broaching Rotation Speed - The basic principle of the 1° offset allows high speed application from 1500 up to 3000 rpm. Rotational speed has very little effect on cutting action or tool life. The cutting edges of the broach tend to dig in to the face of the part as the tool comes in to contact with the rotating material. When there is full contact they are in synchronous rotation. At higher speeds this dig mark will become more pronounced and tool life will suffer. For Best results start the broach operation at a slow rotation and then increase the speed when it is in full contact. Reversing the spindle rotation half way into the part can reduce spiraling.

Feed Rate - The feed choice mainly depends on the material characteristics. In a mild-steel, we recommend $.0012 - .0024$ per revolution. If the machine thrust force is sufficient, the feed can be doubled even tripled as machinability increases. In most cases the maximum feed rate should not exceed $.03 \times$ the profile diameter. A slower feed rate will produce an improved finish with finer lines along the sidewalls of the broached hole. By increasing the feed rate the cutting cycle will be faster but the broaching lines will be more pronounced leaving a coarse finish.

Broach Sharpening – An external or internal broach tool can usually be sharpened one or two times if the tools are in reasonable condition. Only the front face will be re-sharpened with a cutting angle from 4° to 8° .

Broach Setup

Series 2100 & 2160

The 2100 Series holders, 2100 line, and 2160 line do not require centering with an indicator. These heads are designed for machines with more accurate centering built into the machine. This would include Swiss Type, Gang type, and small precision lathes, all of which are designed for small diameter precision turning. It is not generally recommended to use the 2100 series broach head on conventional CNC turret type lathes due to the centering inaccuracy associated with these lathes. With the 2100 series broach head it is essential to use the correct length broach. The overall length of the broaching bit is 28mm +0,30 -0,0 and the shank diameter is 8mm with an h5 tolerance. ****Failure to use the correct length broach OR hitting the bottom of the predrill hole will result in poor broach quality, corners chipping on the tool and damage to the bearing or head.****

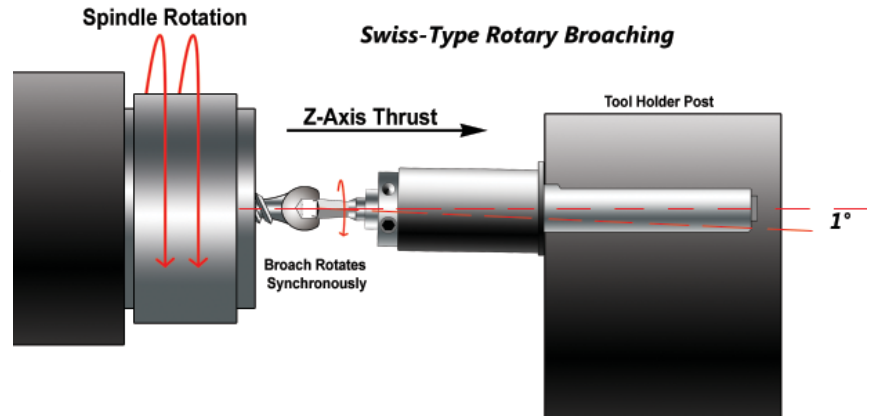

www.rotarybroaching.net

www.genswiss.com

Series 6180, 6190 and 26000

PCM broaching holder series 6180, 6190, 26200 and 26300 are delivered adjusted within .0006" for our standard tools with a 55mm +0.3 length. When tools with different length are used, it is essential to re-adjust the exact centering position. Experience has proven that turret bores are not in perfect alignment with the machine spindle after a certain working time. When misalignment is over .002 of an inch it is necessary to re-adjust the turret positioning to avoid broaching difficulties especially on small sizes.

Pre-Setting for exact centering:

Set the indicator tip (5) on the gage pin (4) at the correct "L". Rotate the holder shank (2) in the preset fixture (1) to obtain a max. TIR of .0008". (Notice the oscillation of the gage pin as it rotates with the holder)

Adjust the position using the 4 adjusting screws and upon completion clamp the head tight with the clamping screws; check again after clamping.

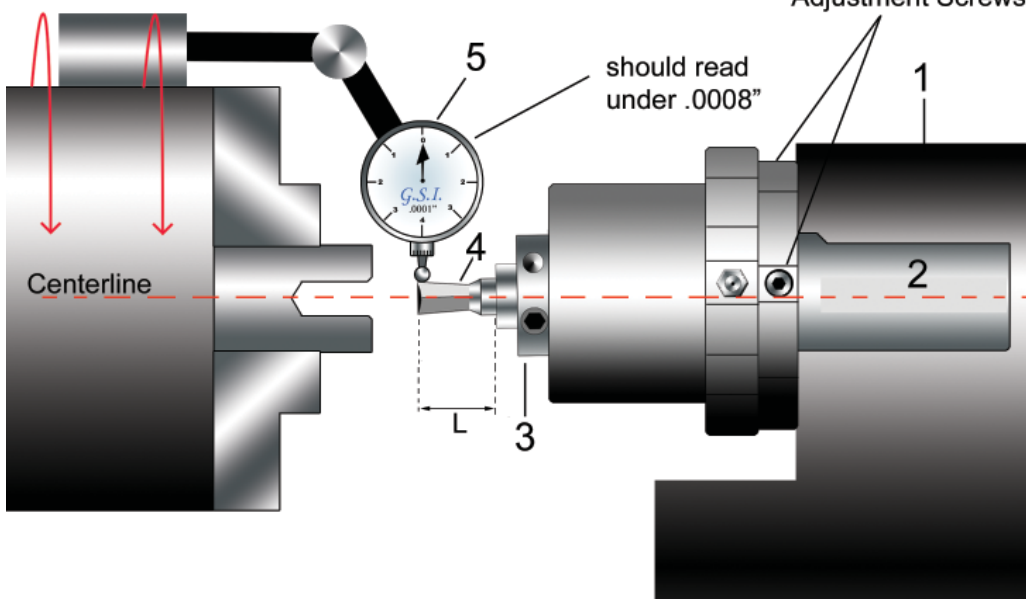
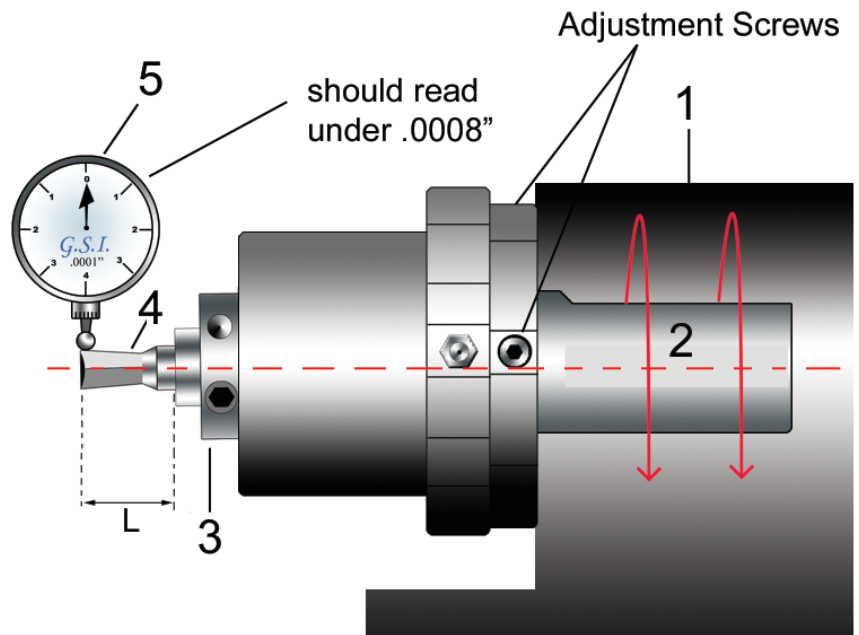

Adjusting Center On The Machine:

Adjustment on the machine offers the advantage to correct misalignment between the machine spindle and the turret bore. The main inconvenience is the adjustment is only valid for that one turret position.

With the gage pin (4) set to the proper "L", set the broach head in the turret station (1) to be used for broaching. Set the indicator (5) on to the spindle chuck with a magnetic base. Place the indicator tip on to the end of the gage pin. Rotate the chuck so the indicator sweeps the diameter of the pin.

Adjust the position using the 4 adjusting screws and upon completion clamp the head tight with the clamping screws; check again after clamping.