



Signature Series Tool Holding Solutions

Rigid & Accurate ID Tool Holding



- Swiss Precision Collet Sleeves
- Double Ended Collet Sleeves
- Coolant-Through Collet Sleeves
- Quick Change Holding Solutions
- Standard & Coolant-Thru ER Collets

www.genswiss.com

1-(413)-562-4800

sales@genswiss.com

6 Old Stage Road, Westfield, MA 01085

SIGNATURE SERIES COLLET SLEEVES



ER Style Collets are the tool holding system of choice for use in CNC machine applications. Swiss Precision collet sleeves provide rigid & accurate holding of ID tooling. These collet sleeves feature ground shanks and tapers. Mini nuts are used to reduce interference and to make setup and tool changing easier than collet sleeves with hexagonal clamping nuts.

Our Single Ended Swiss Precision Sleeves Feature:

- **Locking Flats To Prevent Damage To Sleeve Shank & Provides Orientation For Use With Boring Bars**
- **Precision Ground & Hardened For Accuracy & Precision**
- **Internal Stop Screw Prevents Tool Pushback**

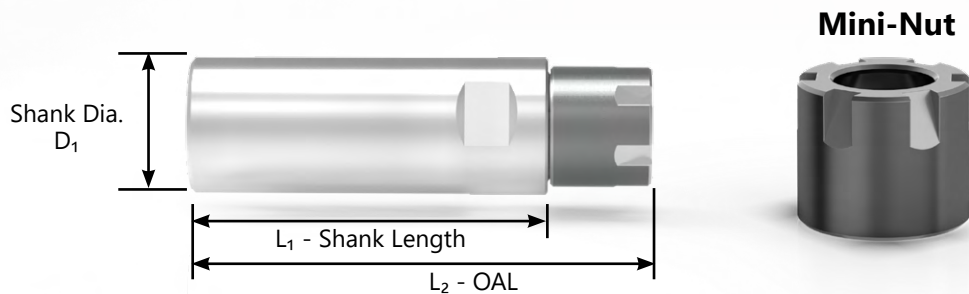

Precision ER Collet Sleeves - Inch Shanks

| Part No. | Collet | Shank Dia. (D ₁) | Shank Length (L ₁) | OAL (L ₂) | With Locking Flat | Stop Screw | Nut Type |
|---------------|--------|------------------------------|--------------------------------|-----------------------|-------------------|------------|-------------|
| CS-08-095-070 | ER08 | 0.375in | 70mm | 93mm | No | No | Mini-Nut |
| CS-11-127-023 | ER11 | 0.5in | 23mm | 30mm | Yes | No | No Mini-Nut |
| CS-11-158-022 | | 0.625in | 22mm | 30mm | Yes | No | No Mini-Nut |
| CS-11-158-050 | | 0.625in | 50mm | 62mm | Yes | Yes | Mini-Nut |
| CS-11-158-100 | | 0.625in | 100mm | 112mm | Yes | Yes | Mini-Nut |
| CS-11-190-070 | | 0.75in | 70mm | 82mm | Yes | Yes | Mini-Nut |
| CS-11-190-115 | | 0.75in | 115mm | 135mm | Yes | Yes | Mini-Nut |
| CS-16-158-075 | | 0.625in | 75mm | 90mm | Yes | Yes | Mini-Nut |
| CS-16-190-035 | | 0.75in | 35mm | 50mm | Yes | Yes | Mini-Nut |
| CS-16-190-050 | | 0.75in | 50mm | 65mm | Yes | Yes | Mini-Nut |
| CS-16-190-070 | | 0.75in | 70mm | 85mm | Yes | Yes | Mini-Nut |
| CS-16-190-100 | ER16 | 0.75in | 100mm | 115mm | Yes | Yes | Mini-Nut |
| CS-16-190-120 | | 0.75in | 120mm | 148mm | Yes | Yes | Mini-Nut |
| CS-16-254-022 | | 1in | 22mm | 37mm | Yes | Yes | Mini-Nut |
| CS-16-254-033 | | 1in | 33mm | 49mm | Yes | Yes | Mini-Nut |
| CS-16-254-038 | | 1in | 38mm | 53mm | Yes | Yes | Mini-Nut |
| CS-16-254-065 | | 1in | 65mm | 80mm | Yes | No | Mini-Nut |
| CS-16-254-075 | | 1in | 75mm | 90mm | Yes | No | Mini-Nut |
| CS-16-254-080 | | 1in | 80mm | 95mm | Yes | Yes | Mini-Nut |
| CS-16-254-100 | | 1in | 100mm | 115mm | Yes | Yes | Mini-Nut |
| CS-16-254-130 | | 1in | 130mm | 145mm | Yes | Yes | Mini-Nut |
| CS-20-254-100 | ER20 | 1in | 100mm | 117mm | Yes | No | Mini-Nut |
| CS-20-254-140 | | 1in | 140mm | 157mm | Yes | No | Mini-Nut |

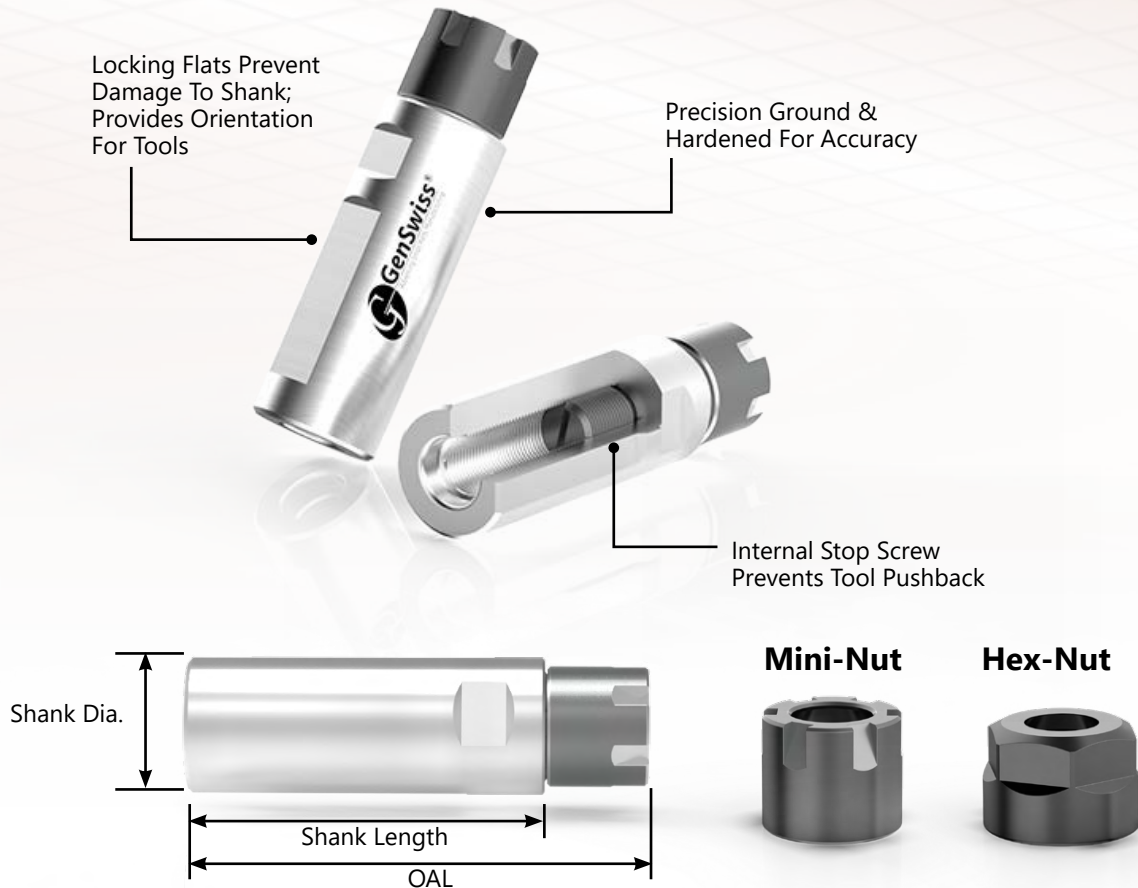

Precision ER Collet Sleeves - Metric Shanks

| Part No. | Collet | Shank Dia. (D ₁) | Shank Length (L ₁) | OAL (L ₂) | With Locking Flat | Stop Screw | Nut Type |
|---------------|--------|------------------------------|--------------------------------|-----------------------|-------------------|------------|----------|
| CS-08-080-080 | ER08 | 8mm | 80mm | 106mm | No | No | Mini-Nut |
| CS-11-080-056 | | 8mm | 56mm | 78mm | No | Yes | Mini-Nut |
| CS-11-160-038 | ER11 | 16mm | 38mm | 51mm | Yes | Yes | Mini-Nut |
| CS-11-200-070 | | 20mm | 70mm | 82mm | Yes | Yes | Mini-Nut |
| CS-16-200-035 | | 20mm | 35mm | 50mm | Yes | Yes | Mini-Nut |
| CS-16-200-070 | | 20mm | 70mm | 85mm | Yes | Yes | Mini-Nut |
| CS-16-200-100 | | 20mm | 100mm | 115mm | Yes | Yes | Mini-Nut |
| CS-16-200-140 | | 20mm | 140mm | 168mm | Yes | Yes | Mini-Nut |
| CS-16-220-070 | ER16 | 22mm | 70mm | 86mm | Yes | Yes | Mini-Nut |
| CS-16-220-100 | | 22mm | 100mm | 116mm | Yes | Yes | Mini-Nut |
| CS-16-250-065 | | 25mm | 65mm | 81mm | Yes | Yes | Mini-Nut |
| CS-16-250-100 | | 25mm | 100mm | 115mm | Yes | No | Hex-Nut |
| CS-16-250-160 | | 25mm | 160mm | 175mm | Yes | No | Hex-Nut |
| CS-20-220-080 | ER20 | 22mm | 80mm | 97mm | Yes | No | Mini-Nut |
| CS-20-250-154 | | 25mm | 154mm | 170mm | Yes | Yes | Mini-Nut |
| CS-25-220-070 | ER25 | 22mm | 70mm | 117mm | Yes | Yes | Mini-Nut |
| CS-25-250-145 | | 25mm | 145mm | 181mm | Yes | Yes | Mini-Nut |

REGO-FIX®

Standard, Ultra-Precision, & Coolant-Thru ER Collets Available

- T.I.R < .0004" Standard
- T.I.R < .0002" Ultra-Precision
- ER8, ER11, ER16, ER20 Sizes
- Inch Diameters (.0625-.5in) & Metric Diameters (1-13mm)
- Coolant-Thru Rated To 2000PSI



SIGNATURE SERIES DOUBLE ENDED COLLET SLEEVES

Double Ended Swiss Precision Sleeves Features:

- Adds Additional ID Tool Positions
- Enables Simultaneous Main & Subspindle Operations
- Precision Ground & Hardened To Ensure High Accuracy

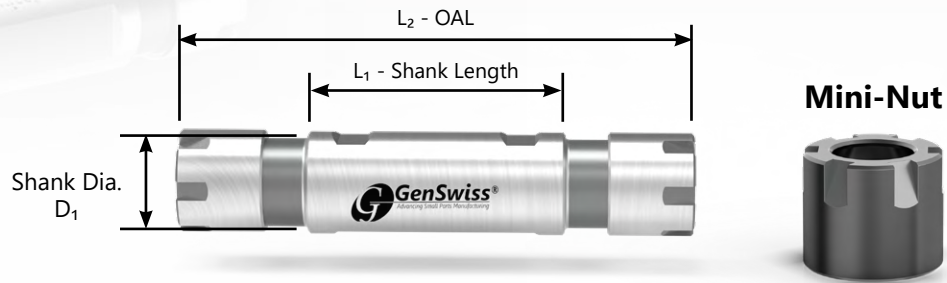

Double Ended Precision ER Collet Sleeves - Inch Shanks

| Part No. | Collet | Shank Dia. (D ₁) | Shank Length (L ₁) | OAL (L ₂) | With Locking Flat | Stop Screw | Nut Type |
|----------------|--------|------------------------------|--------------------------------|-----------------------|-------------------|------------|----------|
| CS-08-158-015D | 8 | 0.625in | 15mm | 45mm | Yes | No | Mini-Nut |
| CS-11-190-035D | | 0.75in | 35mm | 51mm | Yes | No | Mini-Nut |
| CS-11-190-057D | 11 | 0.75in | 57mm | 73mm | Yes | No | Mini-Nut |
| CS-11-190-069D | | 0.75in | 69mm | 85mm | Yes | No | Mini-Nut |
| CS-11-190-096D | | 0.75in | 96mm | 112mm | Yes | No | Mini-Nut |
| CS-16-190-056D | 16 | 0.75in | 56mm | 87mm | Yes | No | Mini-Nut |
| CS-16-254-045D | | 1.0in | 45mm | 75mm | Yes | No | Mini-Nut |
| CS-16-254-075D | | 1.0in | 75mm | 105mm | Yes | No | Mini-Nut |

Double Ended Precision ER Collet Sleeves - Metric Shanks

| Part No. | Collet | Shank Dia. (D ₁) | Shank Length (L ₁) | OAL (L ₂) | With Locking Flat | Stop Screw | Nut Type |
|----------------|--------|------------------------------|--------------------------------|-----------------------|-------------------|------------|----------|
| CS-11-160-050D | ER11 | 16mm | 50mm | 77mm | Yes | No | Mini-Nut |
| CS-11-200-030D | | 20mm | 30mm | 57mm | Yes | No | Mini-Nut |
| CS-11-200-050D | | 20mm | 50mm | 90mm | Yes | No | Mini-Nut |
| CS-16-200-055D | ER16 | 20mm | 55mm | 107mm | Yes | No | Mini-Nut |
| CS-16-220-055D | | 22mm | 55mm | 91mm | Yes | No | Mini-Nut |
| CS-16-220-075D | | 22mm | 75mm | 111mm | Yes | No | Mini-Nut |
| CS-16-250-062D | | 25mm | 62mm | 118mm | Yes | No | Mini-Nut |
| CS-20-320-075D | ER20 | 32mm | 75mm | 107mm | Yes | No | Mini-Nut |
| CS-20-320-110D | | 32mm | 110mm | 142mm | Yes | No | Mini-Nut |

SIGNATURE SERIES COOLANT-FED COLLET SLEEVES

Coolant-Fed Collet Sleeves Features:

- Designed For High-Pressure Coolant Delivery Systems
- Single & Dual Coolant Port Versions Available
- Use With Sealed Coolant-Style ER Collets Or Standard Collets

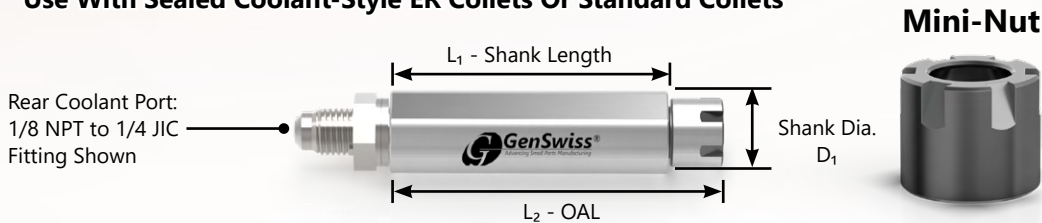

Coolant-Fed ER Collet Sleeves - Inch Shanks

Single Coolant Port

| Part No. | Collet | Shank Dia. (D ₁) | Shank Length (L ₁) | OAL (L ₂) | With Locking Flat | Stop Screw | Nut Type | Rear Coolant Port |
|----------------|--------|------------------------------|--------------------------------|-----------------------|-------------------|------------|----------|-------------------|
| CS-11-190-035C | ER11 | 0.75in | 35mm | 44.5mm | Yes | Yes | Mini-Nut | 1/8 NPT |
| CS-11-190-062C | | 0.75in | 62mm | 71.5mm | Yes | Yes | Mini-Nut | 1/8 NPT |
| CS-16-190-042C | ER16 | 0.75in | 42mm | 55mm | Yes | Yes | Mini-Nut | 1/4 NPT |
| CS-16-190-062C | | 0.75in | 62mm | 75mm | Yes | Yes | Mini-Nut | 1/4 NPT |
| CS-16-190-086C | | 0.75in | 86mm | 100mm | Yes | Yes | Mini-Nut | 1/4 NPT |
| CS-16-254-049C | ER20 | 1in | 49mm | 65mm | Yes | Yes | Mini-Nut | 3/8 NPT |
| CS-20-254-050C | | 1in | 50mm | 67mm | Yes | Yes | Mini-Nut | 3/8 NPT |
| CS-20-254-085C | | 1in | 83mm | 100mm | Yes | Yes | Mini-Nut | 3/8 NPT |

NOTE: A fitting is included with each collet sleeve
NOTE: All shanks include stop screws

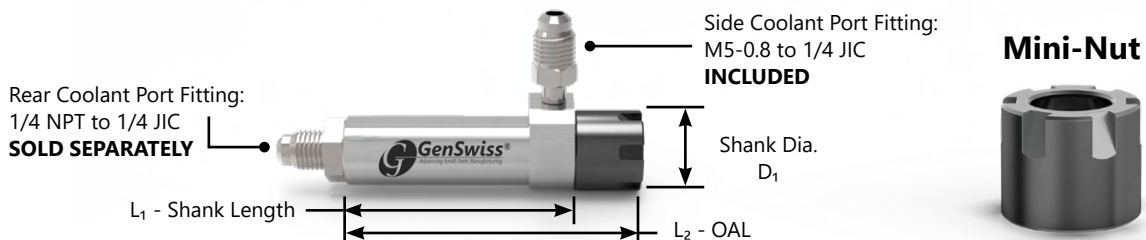

Coolant-Fed ER Collet Sleeves - Inch Shanks

Double Coolant Ports

| Part No. | Collet | Shank Dia. (inch) | Shank Length (inch) | OAL (inch) | With Locking Flat | Nut Type | Side Coolant Port | Rear Coolant Port |
|-----------------|--------|-------------------|---------------------|------------|-------------------|----------|-------------------|-------------------|
| CS-16-190-050GC | 16 | 0.75in | 50mm | 77mm | Yes | Mini-Nut | M5 | 1/4 NPT |
| CS-16-190-060GC | | 0.75in | 60mm | 87mm | Yes | Mini-Nut | M5 | 1/4 NPT |
| CS-16-190-070GC | | 0.75in | 70mm | 97mm | Yes | Mini-Nut | M5 | 1/4 NPT |
| CS-16-254-050GC | | 1.0in | 50mm | 77mm | Yes | Mini-Nut | M5 | 1/4 NPT |

NOTE: A 1/4 NPT plug for the rear coolant port is included

Coolant-Fed ER Collet Sleeves - Metric Shanks

Double Coolant Ports

| Part No. | Collet | Shank Dia. (mm) | Shank Length (mm) | OAL (mm) | With Locking Flat | Nut Type | Side Coolant Port | Rear Coolant Port |
|-----------------|--------|-----------------|-------------------|----------|-------------------|----------|-------------------|-------------------|
| CS-16-200-050GC | 16 | 20mm | 50mm | 77mm | Yes | Mini-Nut | M5 | 1/4 NPT |
| CS-16-200-070GC | | 20mm | 70mm | 97mm | Yes | Mini-Nut | M5 | 1/4 NPT |
| CS-16-220-050GC | | 22mm | 50mm | 77mm | Yes | Mini-Nut | M5 | 1/4 NPT |
| CS-16-220-070GC | | 22mm | 70mm | 97mm | Yes | Mini-Nut | M5 | 1/4 NPT |
| CS-16-250-050GC | | 25mm | 50mm | 77mm | Yes | Mini-Nut | M5 | 1/4 NPT |
| CS-16-250-070GC | | 25mm | 70mm | 97mm | Yes | Mini-Nut | M5 | 1/4 NPT |

NOTE: A 1/4 NPT plug for the rear coolant port is included

QUICK CHANGE TOOL HOLDING SOLUTIONS

These collet sleeves are cost effective solutions to tool holding and are available in a variety of both Inch and Metric sized shank diameters. Also featuring a solid shank for rigidity and a side coolant port for connection to a high-pressure coolant delivery system. Every unit has a notched collet taper for easy tool orientation when combined with Quick-Change boring bar adapters.

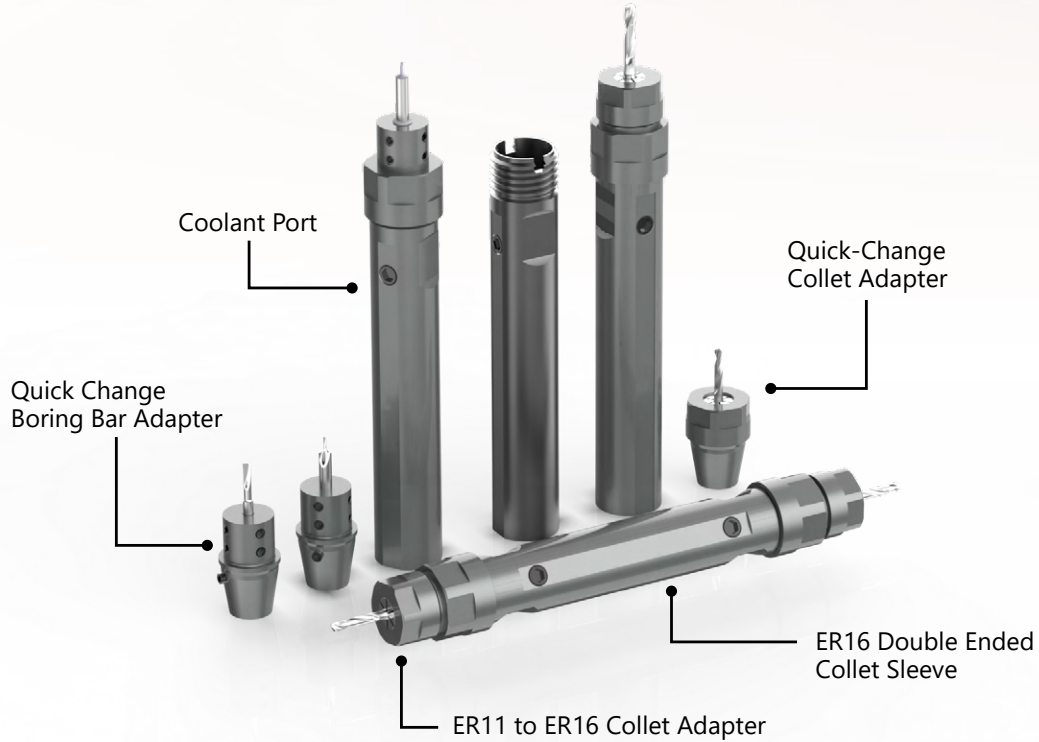

Single Ended Shank Used With The Quick Change Boring Bar Adapter

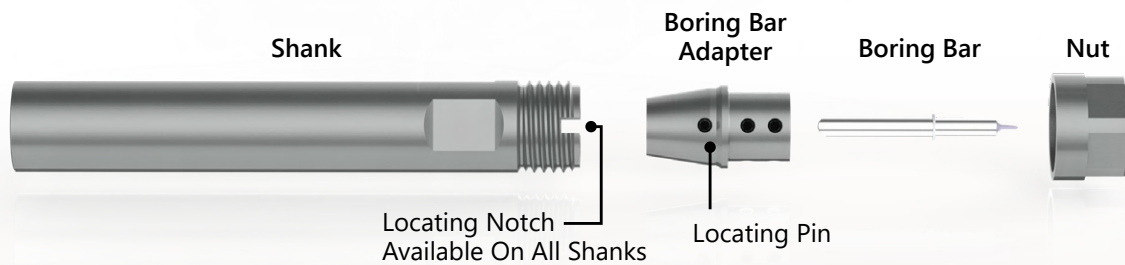

Single Ended Shank Used With The Quick Change Collet Adapter

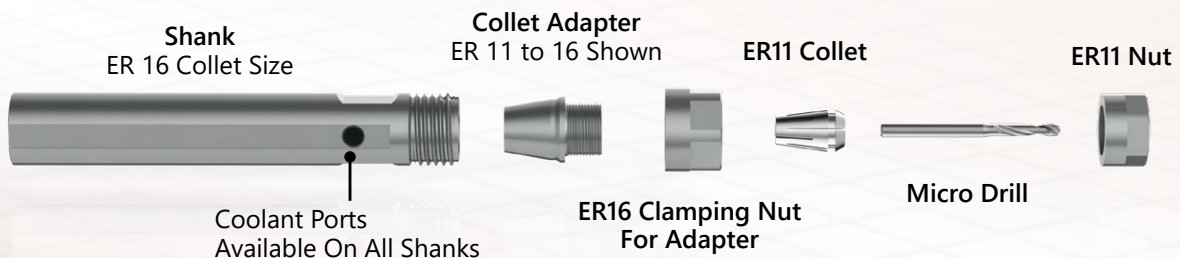

SINGLE ENDED SHANKS

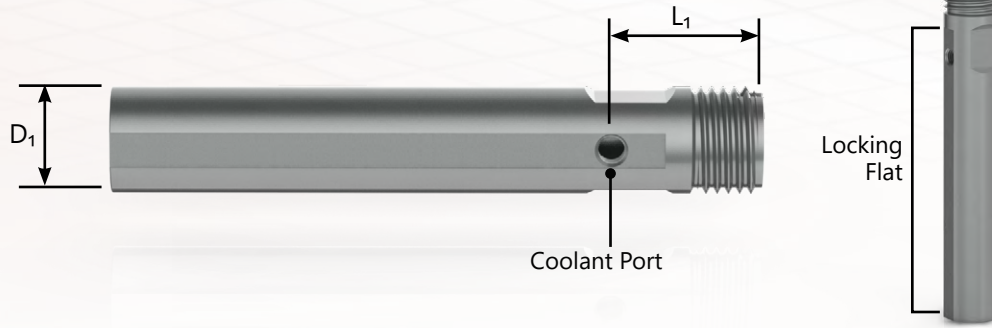

Shank Only - Inch

| Part No. | Collet | D ₁ | L ₁ | OAL |
|---------------|--------|----------------|----------------|-------|
| CQS-SS-160500 | ER16 | .500in | 1.1in | 4.5in |
| CQS-SS-160625 | ER16 | .625in | 1.1in | 4.5in |
| CQS-SS-160750 | ER16 | .750in | 1.1in | 4.5in |
| CQS-SS-161000 | ER16 | 1.00in | 1.1in | 4.5in |
| CQS-SS-200750 | ER20 | .750in | 1.2in | 4.5in |
| CQS-SS-201000 | ER20 | 1.00in | 1.2in | 4.5in |
| CQS-SS-201250 | ER20 | 1.25in | 1.2in | 4.5in |

Shank w/ Nut - Inch

| Part No. W/ Nut |
|------------------|
| CQS-S16-0500-CSE |
| CQS-S16-0625-CSE |
| CQS-S16-0750-CSE |
| CQS-S16-1000-CSE |
| CQS-S20-0750-CSE |
| CQS-S20-1000-CSE |
| CQS-S20-1250-CSE |

Shank Only - Metric

| Part No. | Collet | D ₁ | L ₁ | OAL |
|---------------|--------|----------------|----------------|-------|
| CQS-SS-160787 | ER16 | 20mm | 28mm | 114mm |
| CQS-SS-160866 | ER16 | 22mm | 28mm | 118mm |
| CQS-SS-160984 | ER16 | 25mm | 28mm | 95mm |
| CQS-SS-200866 | ER20 | 22mm | 30mm | 114mm |
| CQS-SS-201260 | ER20 | 32mm | 30mm | 118mm |

Shank w/ Nut - Metric

| Part No. W/ Nut |
|------------------|
| CQS-S16-0787-CSE |
| CQS-S16-0866-CSE |
| CQS-S16-0984-CSE |
| CQS-S20-0866-CSE |
| CQS-S20-1260-CSE |

DOUBLE ENDED SHANKS

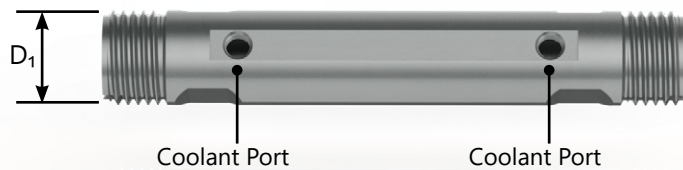

Inch

| Part No. | Collet | D ₁ | OAL |
|------------------|--------|----------------|-------|
| CQS-S16-0750-CDE | ER16 | .750in | 4.5in |
| CQS-S16-1000-CDE | ER16 | 1.00in | 4.5in |
| CQS-S20-1000-CDE | ER20 | 1.00in | 4.5in |

Metric

| Part No. | Collet | D ₁ | OAL |
|------------------|--------|----------------|-------|
| CQS-S16-0866-CDE | ER16 | 22mm | 114mm |
| CQS-S16-0984-CDE | ER16 | 25mm | 95mm |
| CQS-S20-1260-CDE | ER20 | 32mm | 118mm |

NOTE: Each double ended shank is sold with two nuts

SPARE ER COLLET NUTS

| Part No. | ER Size | Nut Thread |
|--------------|---------|------------|
| CQS-NT160001 | ER16 | M19 x 1.0 |
| CQS-NT200001 | ER20 | M24 x 1.0 |
| CQS-NT250001 | ER25 | M32 x 1.5 |

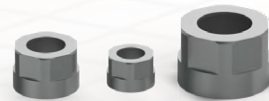

QUICK CHANGE COLLET ADAPTERS

Quick Change collet adapters make it easier to control quality in your shop. These adapters make it simple to have preset tooling available, eliminating the need to touch off the tool after a routine change. This also enables less experienced machine operators to be more productive.

- Simplifies Setup
- Decreases Downtime



Assembly With Collet

| Part No. | Adapter | Collet | Middle Nut Thread |
|-------------------|--------------|--------|-------------------|
| CQS-AS11-0801-xxx | ER11 to ER8 | ER8 | M13 x .75 |
| CQS-AS11-0802-xxx | ER11 to ER8 | ER8 | M14 x .75 |
| CQS-AS16-1101-xxx | ER16 to ER11 | ER11 | M19 x 1 |
| CQS-AS16-1102-xxx | ER16 to ER11 | ER11 | M22 x 1.5 |
| CQS-AS20-1601-xxx | ER20 to ER16 | ER16 | M24 x 1 |
| CQS-AS20-1601-xxx | ER20 to ER16 | ER16 | M25 x 1.5 |

Assembly Only

| Part No. | Adapter | Collet | Middle Nut Thread |
|---------------|--------------|--------|-------------------|
| CQS-AS11-0803 | ER11 to ER8 | ER8 | M13 x .75 |
| CQS-AS11-0804 | ER11 to ER8 | ER8 | M14 x .75 |
| CQS-AS16-1103 | ER16 to ER11 | ER11 | M19 x 1 |
| CQS-AS16-1104 | ER16 to ER11 | ER11 | M22 x 1.5 |
| CQS-AS20-1603 | ER20 to ER16 | ER16 | M24 x 1 |
| CQS-AS20-1604 | ER20 to ER16 | ER16 | M25 x 1.5 |

*replace xxx with desired collet size in nominal inch or millimeter sizes

QUICK CHANGE BORING ADAPTERS

Quick Change Boring adaptors make it fast and simple to locate center position for boring bars when combined with notched ER holders. A simple locating pin rests within the notched holder ensuring accurate centering. These solid bushings utilize the ER collet system to securely hold a boring bar in a rigid fashion. Axial length can be easily set using any form of presetting device.

- *Easily Locates Boring Bar Axial & Radial Position*



ER16 (Inch)

| Part No. | ER Size | Bore | Nut Thread |
|----------------|---------|---------|------------|
| CQS-SH16-12501 | ER16 | .125in | M19 x 1 |
| CQS-SH16-18701 | | .1875in | M19 x 1 |
| CQS-SH16-25001 | | .250in | M19 x 1 |
| CQS-SH16-31201 | | .3125in | M19 x 1 |
| CQS-SH16-37501 | | .375in | M19 x 1 |

ER16 (Metric)

| Part No. | ER Size | Bore | Nut Thread |
|----------------|---------|------|------------|
| CQS-SH16-15701 | ER16 | 4mm | M19 x 1 |
| CQS-SH16-19701 | | 5mm | M19 x 1 |
| CQS-SH16-23601 | | 6mm | M19 x 1 |
| CQS-SH16-31501 | | 8mm | M19 x 1 |

ER20 (Inch)

| Part No. | ER Size | Bore | Nut Thread |
|-----------------|---------|---------|------------|
| CQS-SH20-12501 | ER20 | .125in | M24 x 1 |
| CQS-SH20-187501 | | .1875in | M24 x 1 |
| CQS-SH20-25001 | | .250in | M24 x 1 |
| CQS-SH20-312501 | | .3125in | M24 x 1 |
| CQS-SH20-37501 | | .375in | M24 x 1 |

ER20 (Metric)

| Part No. | ER Size | Bore | Nut Thread |
|----------------|---------|------|------------|
| CQS-SH16-19701 | ER20 | 5mm | M24 x 1 |
| CQS-SH16-23601 | | 6mm | M24 x 1 |
| CQS-SH16-31501 | | 8mm | M24 x 1 |

Additional Size Options Available, please call.